

Modular Valve Series

5.2 to 79 gpm
3000, 3600, 5000 psi

Overview

The modular valve is designed and engineered to integrate multiple hydraulic valve operations into a single unit, which eliminates the need for piping between valves and enables configuration of a

circuit using a single modular valve. The result is an innovative valve system whose energy and materials efficiency provide advantages in terms of

compact configuration, reliability, and more. The illustrations below show one example of a circuit configuration using this system.

Features

- 1 High pressure and high volume. Available maximum operating pressure operations are 3000, 3600, and 5000 psi, while maximum control flow rates are G01 13 gpm, G03 26 gpm, G04 79 gpm.
- 2 Ganging and bolting format allows for quick and easy circuit configuration as well as circuit changes and additions.
- 3 Compact module configurations greatly reduce space requirements.
- 4 Maintenance costs are also reduced because less piping and fewer couplings mean less need for acid rinsing and flushing of pipes.
- 5 Fewer fluid leak problems due to pipe resonance, noise, and loose couplings.
- 6 Circuit configuration is simple yet exact. Nameplates on the side of the valve show ISO codes that make it quick and easy to determine its performance.
- 7 A full lineup of models is available to meet a wide range of needs and circuit configurations: Model G01 (D03), G03 (D05), G04 (D07).

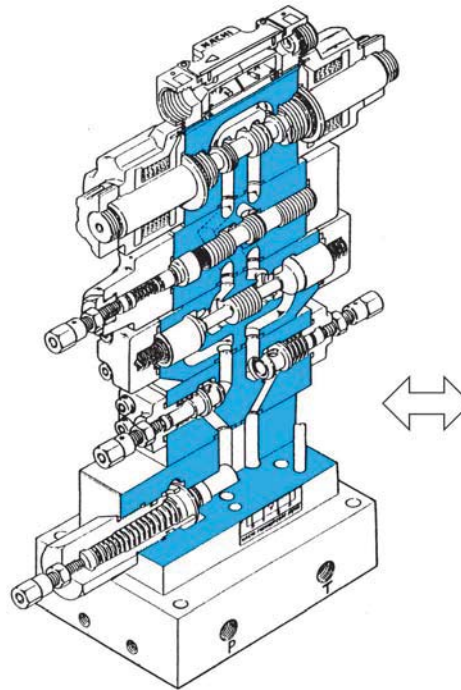

Integrated Structural Diagram

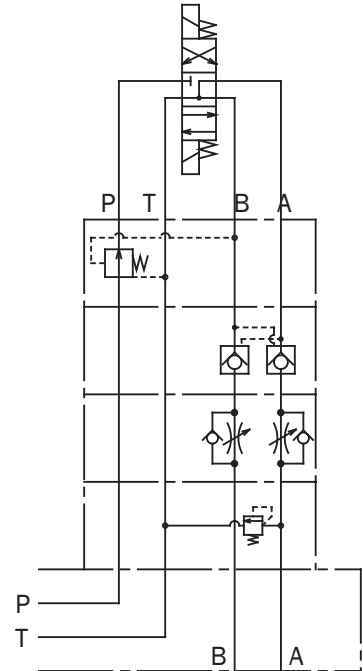

Integrated Circuit Diagram

Specifications

Name	Nominal Diameter (Size)	Maximum Working Pressure psi	Maximum Flow Rate gpm	Gasket Surface Dimensions	Possible Number of Ganged Valves (Note 2)
01 Series	1/8	3600 (Note 1)	13	ISO 4401-03-02-0-94	1 to 4
03 Series	3/8	3600 (Note 1)	26	ISO 4401-05-04-0-94	1 to 4
04 Series	1/2	5000	79	ISO 4401-07-06-0-94	1 to 3 (Note 3)

- Note) 1. The M35 Series is available as a 5000 psi maximum operating pressure version of the 01 and 03 Series. For details, see pages F92 and F93.
 2. The number of ganged valves does not include solenoid valves.
 3. Up to four valves can be ganged together if the maximum operating pressure is less than 3000 psi.

K Series Modular Valve

The valve shown in the photograph is available with nominal diameter 01 and 03 size adjusting bolts. Use the following format for specification.

Example: OCY-G01-W-Y-K-20

Auxiliary symbol
K: With handle

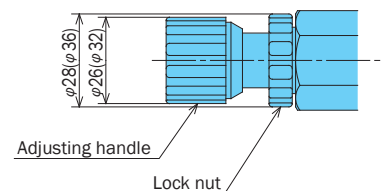

Dimensions in parentheses indicate nominal diameter 03.

Precautions when Ganging Modular Valves

Note the following precautions when ganging modular valves together in the applicable example circuits.

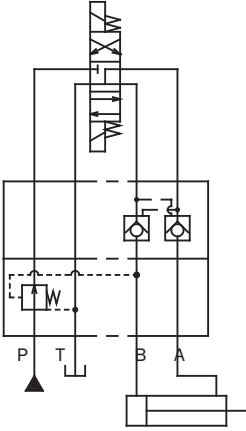
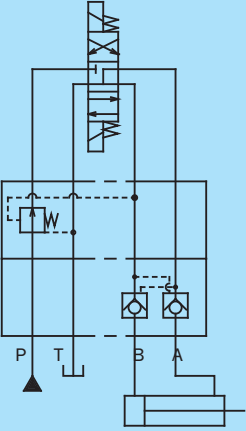
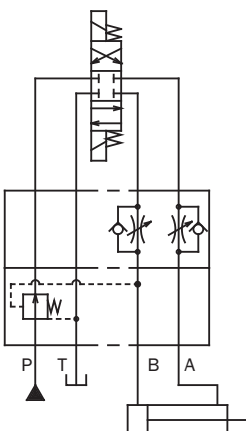
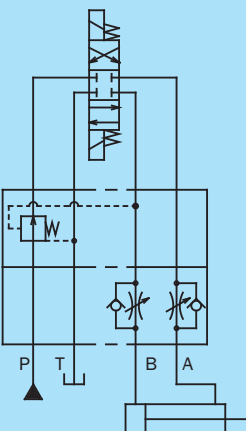
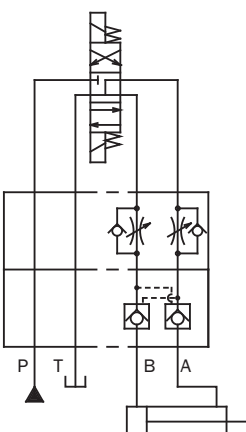
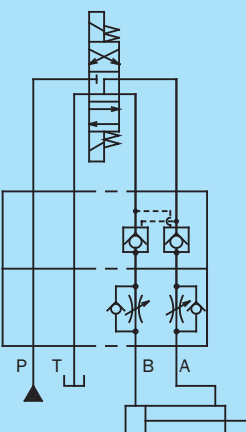
Circuit Diagram	Description	Incorrect	Correct
<p>Locking Circuit and Pressure Reducing Circuit</p>	<ul style="list-style-type: none"> ● Cylinder position not maintained ○ Leaks occur because, during the pilot check, the line being maintained flows into the pilot line of the reducing valve. 	<p>Solenoid</p> <p>Pilot Operate Check Modular Valve (AB Line)</p> <p>Pressure Reducing Modular Valve (B Line)</p> 	
<p>Pressure Reduction Circuit with Speed Control</p>	<ul style="list-style-type: none"> ● Insufficient cylinder output and drop in speed ○ Pressure increases due to the restrictor effect of the flow regulator. Since the pilot runs from that line, pressure reduction makes smooth operation impossible. 	<p>Solenoid</p> <p>Flow Regulator Modular Valve (A, B Line, Meter Out)</p> <p>Pressure Reducing Modular Valve (B Line)</p> 	
<p>Locking Circuit and Speed Control Circuit</p>	<ul style="list-style-type: none"> ● Cylinder knocking ○ Pressure is increased by the restrictor effect of the flow regulator. That pressure moves the pilot check in the closed direction, which causes the valve to repeatedly open and close. 	<p>Solenoid</p> <p>Flow Regulator Modular Valve (A, B Line, Meter Out)</p> <p>Pilot Operate Check Modular Valve (AB Line)</p> 	

Valve Ganging Configuration Examples

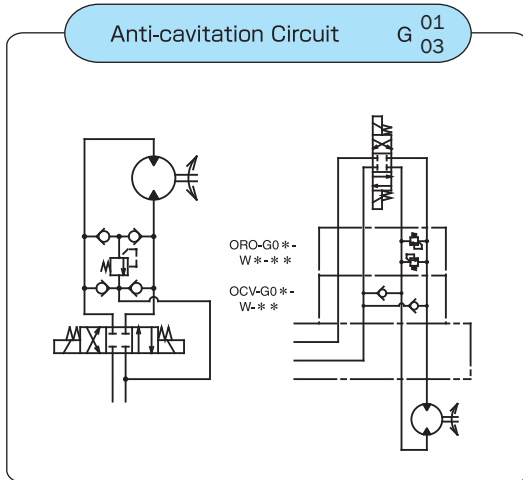

- Surge pressure is prevented by the inertia of the actuator, and cavitation by fluid being sucked in through the opposite port, which is in negative pressure, is prevented.
- Example Valve Model Numbers (G03)
Relief Valve _____ ORO-G03-W*-J50
Vacuum Check Valve _____ OCV-G03-W-J50

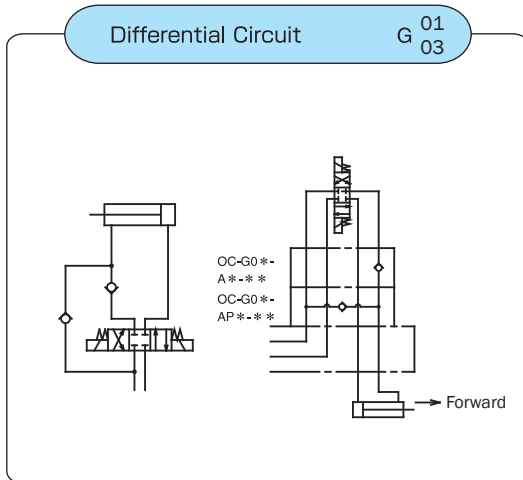

- When the cylinder advances, the rod side return fluid returns to the P port and the pump discharge rate and confluence are advanced at high speed (differential).
- Example Valve Model Numbers (G03)
Check valve _____ OC-G03-A*-J50
Differential check valve _____ OC-G03-AP*-J50

Important:
Cylinder effective output is the rod surface area portion only.

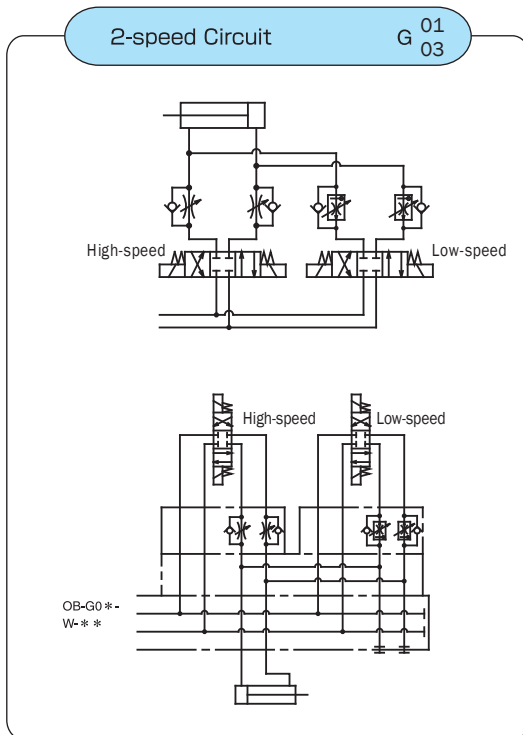

- This type of circuit allows variation between two actuator speeds. It prevents low-speed shock when the actuator starts up or stops, and is used when the intermediate stroke is operated at high speed.
- Example Valve Model Numbers (G03)
2-speed Plate _____ OB-G 03-W-(H)-J 30
High-speed Flow Regulator Valve _____ OCY-G-03-W-YJ51
Low-speed Flow Control Valve _____ OCF-G03-W60-Y-J50

G01 Modular Valve Series

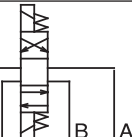
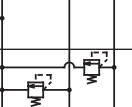
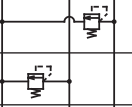
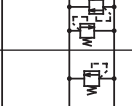
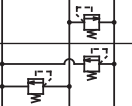
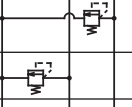
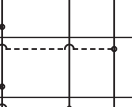
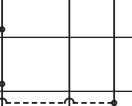
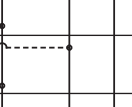
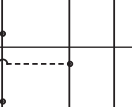
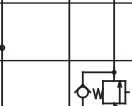
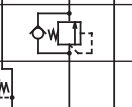
Type	Name	Valve Model Number	Pressure Adjustment Range (Check Valve Cracking Pressure) psi	Maximum Flow Rate gpm	JIS Symbol	Height in	Weight lbs	Catalog Page	
Solenoid Valves	Solenoid Valve	SS-G01-**-R**-31		13		1.57	3.3	D-4 D-16	
		SA-G01-**-**-31							
Pressure Control Valves	Relief Valves (Balance Type)	OR-G01-P $\frac{1}{3}$ -20	1: 145 to 1000	13		1.57	5.0	F-10	
		-W $\frac{1}{3}$ -20	3: 500 to 3600						
		-A $\frac{1}{3}$ -21							
		-B $\frac{1}{3}$ -21							
	Brake Valves (Direct Type)	ORO-G01-W $\frac{1}{3}$ -20	1: 115 to 1000	5.2		1.57	3.0	F-16	
		-A $\frac{1}{3}$ -20	3: 500 to 3600						
		-B $\frac{1}{3}$ -20							
	Direct Relief Valves (Direct Type)	ORD-G01-W $\frac{1}{3}$ -20	1: 115 to 1000	5.2		1.57	3.0	F-20	
		-A $\frac{1}{3}$ -20	3: 500 to 3600						
		-B $\frac{1}{3}$ -20							
	Reducing Valves (Direct Type)	OG-G01-P $\frac{C}{1-21}$	C: 20 to 500	13		1.57	2.8	F-25	
		$\frac{C}{1-21}$	1: 115 to 1000						
		$\frac{C}{1-21}$	2: 500 to 3000						
	Balance Type Reducing Valves	OGB-G01-P $\frac{C}{1-20}$	C: 20 to 500	10.5		1.57	4.1	F-32	
		-A $\frac{1-20}{3}$	1: 115 to 1000						
		-B $\frac{1-20}{3}$	3: 500 to 3000						
	Reducing Valves (Direct Type)	OG-G01-A $\frac{C}{1-E21}$	C: 20 to 500	10.5		1.57	2.8	F-34	
		OG-G01-B $\frac{C}{1-E21}$	2: 500 to 3000						
Pressure Control Valves (Sequence Valves)	OQ-G01-P2 $\frac{1}{3}$ -20	1: 115 to 1000 3: 500 to 3000	10.5		1.57	2.4	F-44		
Pressure Control Valves (Counter Balance Valves)	OCQ-G01-A1 $\frac{1}{2}$ -20	1: 115 to 1000 2: 500 to 2000					F-47		
Pressure Switches	Pressure Switches	OW-G01-P $\frac{C}{1-R}$ -**-30	C: 72 to 500	13		1.57	3.9	F-52	
		-W $\frac{C}{1-R}$ -**-30	1: 115 to 1000 3: 500 to 3000						
		-A $\frac{C}{1-R}$ -**-30	Contact Capacitance AC 125V:5A DC 12V:2.2A DC 24V:1.1A						
		-B $\frac{C}{1-R}$ -**-30							
Flow Control Valve	Flow Regulator Valve	OY-G01-T-20		13		1.57	2.2	F-55	
	Flow Regulator Valves with Check	OCY-G01-P-20	5.8						
	Meter-Out Flow Regulator Valves	OCY-G01-W-Y-20		11.6	13		1.57	2.8	F-55
		-A-Y-20							
		-B-Y-20					2.6	F-63	

G01 Modular Valve Series

Type	Name	Valve Model Number	Pressure Adjustment Range (Check Valve Cracking Pressure) psi	Maximum Flow Rate gpm	JIS Symbol	Height in	Weight lbs	Catalog Page	
Flow Control Valves	Meter-in Flow Regulator Valve	OCY-G01-W-X-20	11.6	13		1.57	2.8	F-55	
		-A-X-20					2.6		
		-B-X-20					2.6		
	Flow Control Valve (compensated)	OF-G01-P20-20	(Control Flow Rate) Differential Pressure 1000: 2.6 to 10.5 Differential Pressure 3000: .13 to 10.5	10.5		1.57	2.6	F-63	
	Meter-out Flow Control Valves (compensated)	OCF-G01-W40-Y-30	3.7						
		-A40-Y-30	3.3						
		-B40-Y-30	3.7						
	Meter-in Flow Control Valves (compensated)	OCF-G01-W40-X-30	(Control Flow Rate) Differential Pressure 1000: 2.6 to 10.5 Differential Pressure 3600: .13 to 10.5				3.7		
		-A40-X-30	3.3						
	Direction Control Valve	Check Valves	OC-G01-P 1 2-20 3	Cracking pressure 1: 5.8 2: 50 3: 72 *For differential circuit	13		1.57	2.2	F-69
T 2-20 3			2.6						
1 -A 2-21 * 3			2.2						
1 -AP 2-20 * 3			2.2						
Vacuum Check Valves		OCV-G01-W-20	2	13		1.57	2.2	F-76	
Pilot Check Valves		OCP-G01-W 1/2(F)-21	Cracking pressure 1: 29 2: 72 (Auxiliary Symbol) Open Valve Ratio Standard: Parent Valve 37% F: Child Valve 6% : Parent Valve 51%	13		1.57	2.6	F-76	
		-A 1/2(F)-21							
	-B 1/2(F)-21								
Composite Valves	2-pressure Reducing Valves	OGS-G01-P C 1 C-K(R)-**-.22 High pressure side Low pressure side Power supply : C1, C2, D1, D2	C: 29 to 500 1: 115 to 1000 2: 500 to 2000	10.5		3.5	10.5	F-41	
Other	Gauge Modular Blocks	OK-G01-P-(H)-E20	-	13		1	1.3	F-81	
		-T-(H)-E20					1.3		
		-W-(H)-E20					1.3		
	2-speed Plates	OB-G01-W-(H)-20	-	13		1	3.3	F-83	
	End Plates	MOB-G01-(H)-10	-	-	-		20 1.41	0.3 0.6	F-85
		MOB-G01-A-10	-	-	-		1.41	0.6	
	Free-flow plate	-B-10	-	-	13		1.41	0.6	F-90
		MOB -01X-B*-10	B: A, B ports *: Sequential number from 2 to 6 Single side outlet	-	-		1.41	0.6	
Base Blocks (Multi-block)	-01Y-W*-10	W: A, B ports Sequential number from 1 to 6 Dual side outlet	-	-		-	-	F-90	
	MSA-01Y-10 MSA-01Y-T-10	None: Back side outlet T: Side outlet	-	-		-	-	H-4	

G03 Modular Valve Series

Type	Name	Valve Model Number	Pressure Adjustment Range (Check Valve Cracking Pressure) psi	Maximum Flow Rate gpm	JIS Symbol	Height in	Weight lbs	Catalog Page
Solenoid Valves	Solenoid Valves	SS-G03-**-R-**-E21-21 SA-G03-**-** -E21-21		26				D-4 D-16
Pressure Control Valve	Relief Valves (Balance Type)	OR-G03-P $\frac{1}{3}$ -E50	1: 1000 3: 500 to 3600 (Auxiliary Symbol) V: With vent port	21		2.1	6.8	F-10
		-W $\frac{1}{3}$ -E50					8.5	
		-A $\frac{1}{3}$ -E50					6.8	
		-B $\frac{1}{3}$ -E50					6.8	
		OR-G03-P $\frac{1}{3}$ -V-J50					6.8	
	Brake Valves (Direct Type)	ORO-G03-W $\frac{1}{3}$ -J50	1: 115 to 1000 3: 500 to 3600	7.9		2.1	10.5	F-16
		-A $\frac{1}{3}$ -J50					8.8	
		-B $\frac{1}{3}$ -J50					8.8	
	Direct Relief Valves (Direct Type)	ORD-G03-W $\frac{1}{3}$ -J50	1: 115 to 1000 3: 500 to 3600	7.9		2.1	8.5	F-20
		-A $\frac{1}{3}$ -J50					6.8	
		-B $\frac{1}{3}$ -J50					6.8	
	Reducing valve	OG-G03-P $\frac{C}{1-(B)-E51}$	C: 36 to 500 1: 115 to 1000 3: 500 to 3000	21 However, C: 13		2.1	7.9	F-25
		-A $\frac{C}{1-(B)-E51}$					7.9	F-34
-B $\frac{C}{1-(B)-E51}$		7.9					F-34	
Pressure Control Valves (Sequence Valves)	OQ-G03-P2 $\frac{A}{C-J50}$ E	A: 36 to 125 C: 125 to 500	21		2.1	7.7	F-44	
	OCQ-G03-A1 $\frac{A}{C-J50}$ E -B1C-J50 E	E: 500 to 2000				7.7		F-47
Flow Control Valve	Flow Regulator Valve	OCY-G03 $\frac{-P}{-P-H}$ -J50	(Function) H: High differential pressure regulator 14.5	26		2.1	6.3	F-55
	Meter-Out Flow Regulator Valves	-W-Y -W-HY -J51					6.8	
		-A-Y -A-HY -J51					6.8	
		-B-Y -B-HY -J51					6.6	

*There is no problem with seals and other parts when mixing these valves with NACHI G03 modular valve design number (J) 30 valves.

*G03 module valve installation bolts
For M6: Design number J50
For M8: Design number 50
For E: 1/4 - 20UNC
Unit has commonality. Also, two J-pins have been inserted diagonally for M6 applications.

Note: G03 series modular valves have two T port locations: one on the A port side T_(A) and one on the B port side T_(B). The port that is used depends on the model number.

G03 Modular Valve Series

Type	Name	Valve Model Number	Pressure Adjustment Range (Check Valve Cracking Pressure) psi	Maximum Flow Rate gpm	ISO Symbol	Height in	Weight lbs	Catalog Page	
Flow Control Valve	Meter-in Flow Regulator Valve	OCY-G03 -W-X -J51 -W-HX -J51	(Function) H: High differential pressure regulator 14.5	26		2.16	6.8	F-55	
		-A-X -J51 -A-HX -J51							6.6
		-B-X -J51 -B-HX -J51							6.6
	Flow Control Valve (compensated)	OF-G03-P60-J50	(Control Flow Rate) Differential Pressure 1000: .07 to 15.8 Differential Pressure 3600: .13 to 15.8	15.8		2.16	6.8	F-63	
	Meter-out Flow Control Valves (compensated)	OCF-G03-W60-Y-J50	(Volume control flow rate) Differential Pressure 1000: .13 to 15.8 Differential Pressure 3600: .02 to 15.8	15.8		2.16	11		
		-A60-Y-J50					10.1		
		-B60-Y-J50					10.1		
	Meter-in Flow Control Valves (compensated)	OCF-G03-W60-X-J50	(Volume control flow rate) Differential Pressure 1000: .13 to 15.8 Differential Pressure 3600: .02 to 15.8	15.8		2.16	11		
		-A60-X-J50					10.1		
		-B60-X-J50					10.1		
Direction Control Valve	Check Valves	OC-G03-P 1 2-J50 3	Cracking pressure 1: 5.8 2: 50 3: 72 *For differential circuit 	26		2.16	5.9	F-69	
		T 2-J50 3							
		-A 2-J50 * 3							
		-AP 2-J50 * 3							
	Vacuum Check Valves	OCV-G03-W-J50	2.1	26		2.16	7.7	F-69	
	Pilot Check Valves	OCP-G03-W 1/2 (D)-J50	Cracking pressure 1: 29 2: 72 (Auxiliary Symbol) Open Valve Ratio Standard : Child Valve 7% : Parent Valve 49% D : Parent Valve 49%	26		2.16	7.9	F-76	
		-A 1/2 (D)-J50							
-B 1/2 (D)-J50									
Other	Gauge Block	OK-G03-E50		26		2.16	5.0	F-81	
	2-speed Plates	OB-G03-W-(H)-J30		26		1.25 (H:58)	1.4 (H:2.5)	F-83	
	End Plates	MOB-G03-J50: For M6 MOB-G03-(H)-50: For M8		-			1.25 (H:58)	1.4 (H:2.5)	F-85
		MOB-G03-A-J50: For M6 MOB-G03-A-(H)-50: For M8 MOB-G03-B-J50: For M6 MOB-G03-B-(H)-50: For M8		26		1.25 (H:58)	1.3 (H:2.3)		
	Conversion plate (For 03/01 conversion)	MOB-G03-AA-50 MOB-G03-AA-J50		13		1.77	5.0		
	Base Blocks	MOB-03-B*-J30	*:Sequential number from 2 to 5 A, B port dual side outlet			SAE 3/4 SAE 1/2			F-91
	Sub Plate	MSA-03-E10 MS-03(X)-E10 MSA-03(X)-T-E10 MS-03(X)-T-E10	Bottom Outlet Bottom Outlet Side outlet Side outlet						D-9
					SAE 3/8 (SAE 1/2)		H-5		

G03 Modular Valve Series Detailed ISO Symbols

Type	Valve Model Number	Detailed ISO Symbols	Type	Valve Model Number	Detailed ISO Symbols	
Solenoid Valves	SS-G03-**-R-**-E21 -21 SA-G03-**-*** -E21 -21 <small>For M6, M8</small>		Flow Control Valve	OF-G03-P60-J50		
	Pressure Control Valve	OR-G03-P 1/3-E50			OCF-G03-W60-Y-J50	
OR-G03-W 1/3-E50				OCF-G03-A60-Y-J50		
OR-G03-A 1/3-E50				OCF-G03-B60-Y-J50		
OR-G03-B 1/3-E50				OCF-G03-W60-X-J50		
OR-G03-P 1/3-V-J50				OCF-G03-A60-X-J50		
ORO-G03-W 1/3-E50				OCF-G03-B60-X-J50		
ORO-G03-A 1/3-J50				Direction Control Valve	OC-G03-P 1/2-J50 3	
ORO-G03-B 1/3-J50					OC-G03-T 1/2-J50 3	
ORD-G03-W 1/3-J50					OC-G03-A 1/2-J50 3	
ORD-G03-A 1/3-J50			OC-G03-AP 1/2-J50 3			
ORD-G03-B 1/3-J50			OCV-G03-W-J50			
OG-G03-P C 1-(B)-E51 3			OCP-G03-W 1/2-J50			
OG-G03-A C 1-(B)-E51 3			OCP-G03-A 1/2-J50			
OG-G03-B C 1-(B)-E51 3			OCP-G03-B 1/2-J50			
OG-G03-P C 1-(B)-V-J51 3			OK-G03-J50			
OQ-G03-P2 A C-J50 E			Other		OB-G03-W-J30	
OCQ-G03-A1 A C-J50 E				MOB-G03-(H)-50		
OCQ-G03-B1 A C-J50 E				MOB-G03-J50		
Flow Control Valve	OCY-G03-P-J50			MOB-G03-A-(H)-50		
	OCY-G03-W-Y-J51			MOB-G03-A-J50		
	OCY-G03-A-Y-J51			MOB-G03-B-(H)-50		
	OCY-G03-B-Y-J51			MOB-G03-B-J50		
	OCY-G03-W-X-J51			MOB-G03-AA-50		
	OCY-G03-A-X-J51			MOB-G03-AA-J50		
	OCY-G03-B-X-J51			MOB-03X-B*-50		
			MOB-03X-B*-J50			
		MS-03(X)-30				
		MSA-03(X)-10				
		MS-03(X)-T-10				
		MSA-03(X)-T-10				

G04 Modular Valve Series

Type	Name	Valve Model Number	Maximum Working psi	Maximum Flow Rate gpm	Pressure Adjustment Range (Check Valve Cracking Pressure) psi	JIS Symbol	Weight lbs	Catalog Page	
Solenoid Valves	Solenoid Control Valves	DSS-G04-****-R**-21	35MPa 5000	79			33	D-41	
Pressure Control Valve	Relief valve	ORH-G04-P $\frac{1}{3}$ -10 5	35MPa 5000	79	1: 115 to 1000 3: 500 to 3600		15.4	F-10	
	Direct Relief Valves	ORH-G04-DW- $\frac{1}{3}$ -10 5		13.2	1: 115 to 1000 3: 500 to 3600 5: 1000 to 5000		14.3	F-20	
		ORH-G04-DA $\frac{1}{3}$ -10 5			79		1: 115 to 1000 3: 500 to 3600	17.6	F-25
		ORH-G04-DB $\frac{1}{3}$ -10 5					17.6	F-32	
	Reducing valve	OGH-G04-P $\frac{1}{3}$ (B)-10		79	1: 115 to 1000 3: 500 to 3600 (Auxiliary Symbol) B: External drain		17.6	F-47	
		OGH-G04-A $\frac{1}{3}$ (B)-10			17.6		F-47		
		OGH-G04-B $\frac{1}{3}$ (B)-10			17.6		F-47		
	Counter Balance Valves	OQH-G04-A1 $\frac{A}{C}$ -10 E		79	A: 36 to 125 C: 72 to 500 E: 290 to 2000		17.6	F-55	
		OQH-G04-B1 $\frac{A}{C}$ -10 E			17.6		F-55		
	Flow Control Valve	Flow Regulator Valves		OYH-G04-P-10	79		Check Valve Cracking Pressure 5.8		10.3
Meter-in Flow Regulator Valve		OYH-G04-W-X-10	79	Check Valve Cracking Pressure 14.5		14.3	F-55		
		OYH-G04-A-X-10				14.3			
		OYH-G04-B-X-10				14.3			
Meter-Out Flow Regulator Valves		OYH-G04-W-Y-10	79	Check Valve Cracking Pressure 14.5		14.3	F-63		
		OYH-G04-A-Y-10				14.3			
Meter-in Flow Control Valves		OFH-G04-W200-X-10	52.8	Check Valve Cracking Pressure 14.5		24.4	F-69		
		OFH-G04-A200-X-10				22.5			
		OFH-G04-B200-X-10				24.4			
		OFH-G04-W200-Y-10				22.5			
		OFH-G04-A200-Y-10				24.4			
		OFH-G04-B200-Y-10				22.5			
Direction Control Valve		Check Valves	OCH-G04-P $\frac{1}{2}$ -10 3	79	1: 5.8 2: 50 3: 72		9.9	F-69	
			OCH-G04-T $\frac{1}{2}$ -10 3				14.3		
	OCH-G04-A $\frac{1}{2}$ -10 3		9.9						
	OCH-G04-AP $\frac{1}{2}$ -10 3		9.9						
	Vacuum Check Valves	OVH-G04-W-10	79	14.5		14.3	F-69		
	Pilot Check Valves	OPH-G04-W $\frac{1}{2}$ (D)-10	79	1: 29 2: 72 (Auxiliary Symbol) Open Valve Ratio Standard : Child Valve 7% : Parent Valve 50% D : Parent Valve 50%		15	F-76		
		OPH-G04-A $\frac{1}{2}$ (D)-10							
		OPH-G04-B $\frac{1}{2}$ (D)-10							

The G04 series modular valves do not have an L (DR₂) drain port, so they cannot be used in combination with pressure center type solenoid valves (D).



Direct Relief Modular Valve

5.2 to 13.2 gpm
115 to 3045, 3625, 5075 psi

Features

- 1 This modular relief valve provides maximum pressure control for a hydraulic circuit.
- 2 Wide ranging applicability Maximum Working Pressure: 3625, 5075 psi.
- 3 Pressure Adjustment Range: 115 to 3045, 3625, 5075 psi.

Specifications

Model No.	Nominal Diameter (Size)	Maximum Working Pressure psi	Maximum Flow Rate gpm	Pressure Adjustment Range psi	Weight lbs	Gasket Surface Dimensions
ORD-G01-W1-20 W3	1/8	3625	5.2	115 to 1000 500 to 3045	3.3	ISO 4401-03-02-0-94
ORD-G01-A1-20 A3				115 to 1000 500 to 3045	3.0	
ORD-G01-B1-20 B3				115 to 1000 500 to 3045	3.0	
ORD-G03-W1-J50 W3	3/8	3625	7.9	115 to 1000 500 to 3625	10.5	ISO 4401-05-04-0-94
ORD-G03-A1-J50 A3				115 to 1000 500 to 3625	8.8	
ORD-G03-B1-J50 B3				115 to 1000 500 to 3625	8.8	
ORH-G04-DW1-10 DW3 DW5	1/2	5075	13.2	115 to 1000 500 to 3625 1000 to 5075	14.3	ISO 4401-07-06-0-94
ORH-G04-DA1-10 DA3 DA5				115 to 1000 500 to 3625 1000 to 5075	14.3	
ORH-G04-DB1-10 DB3 DB5				115 to 1000 500 to 3625 1000 to 5075	14.3	

• Handling

- 1 The pressure adjustment range is expressed using cracking pressure.
- 2 For use as a safety valve, use a pressure override that is higher than the required circuit pressure.
- 3 Tank port back pressure changes cracking pressure by the corresponding amount.
- 4 Note that a sub plate and installation bolts are not included. See pages H4 and F87-89 if these items are required.
- 5 04 series modular valves do not have an L (DR2) drain port, so they cannot be used in combination with pressure center type solenoid valves (D).

Understanding Model Numbers

01, 03 size

ORD - G 03 - W 3 - (K) - J50

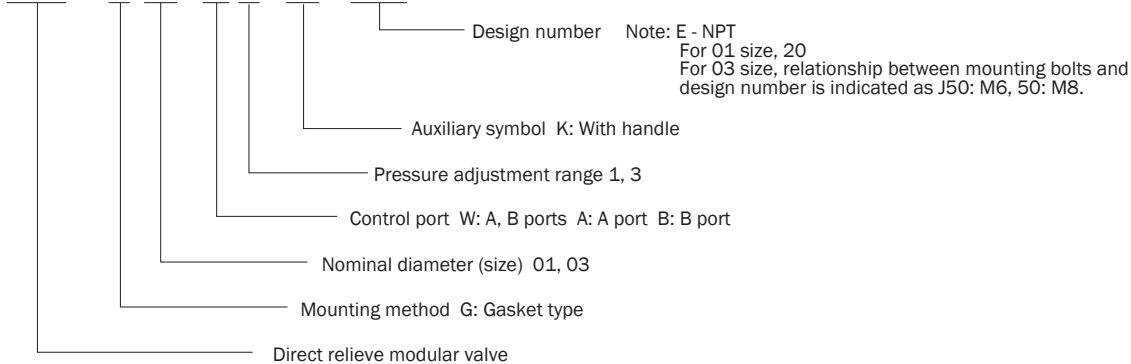

Understanding Model Numbers

04 size

ORH - G 04 - D W 5 - 10

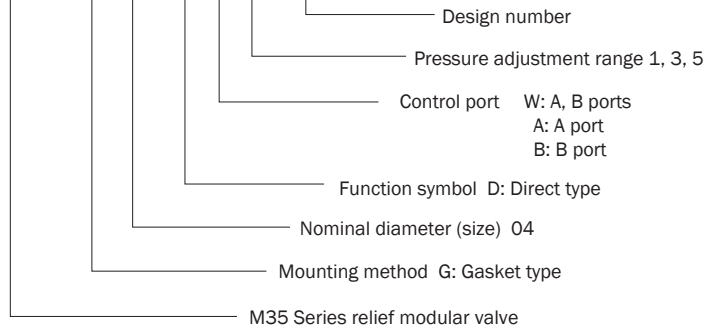

Understanding Model Numbers

Note: Pressure is increased by clockwise (rightward) rotation of the adjusting screw (bolt), and decreased by counterclockwise (leftward) rotation

ORD-G01-W*-20

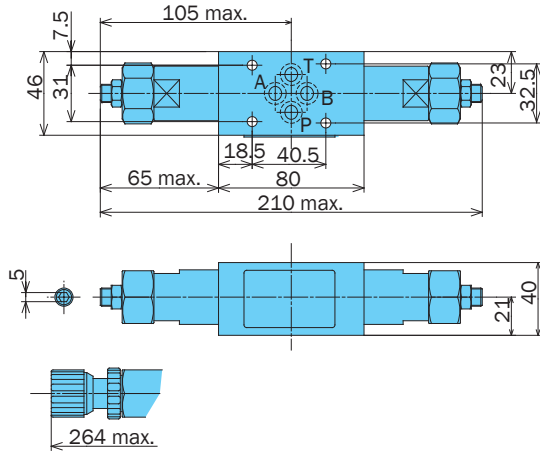

ORD-G01-A*-20

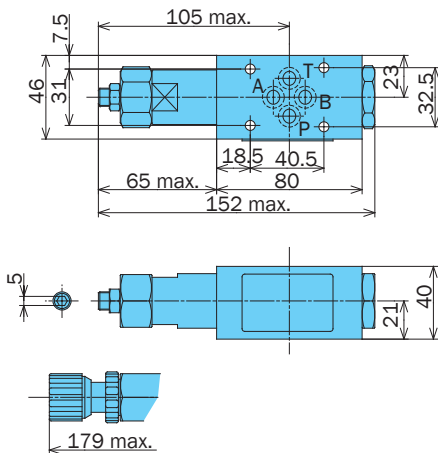

ORD-G01-B*-20

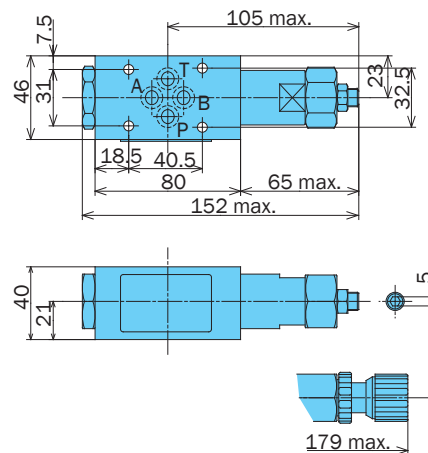

ORD-G03-W*-J50

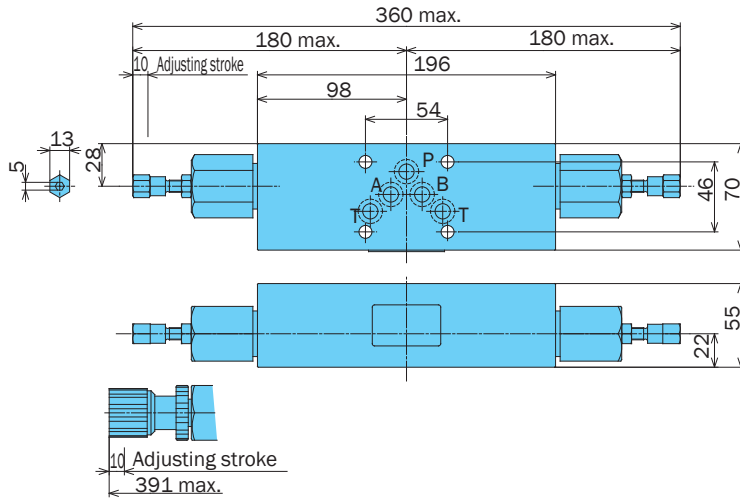

ORD-G03-A*-E50

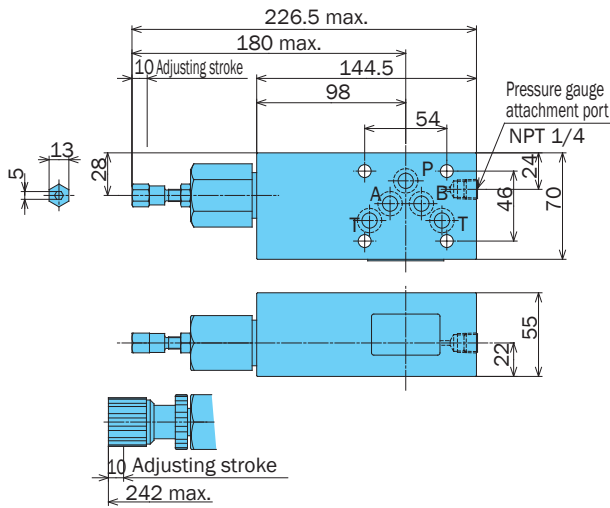

ORD-G03-B*-E50

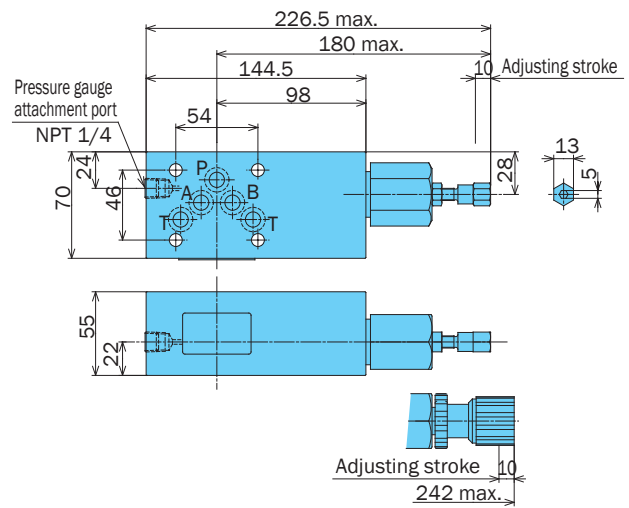

ORH-G04-DW*-10

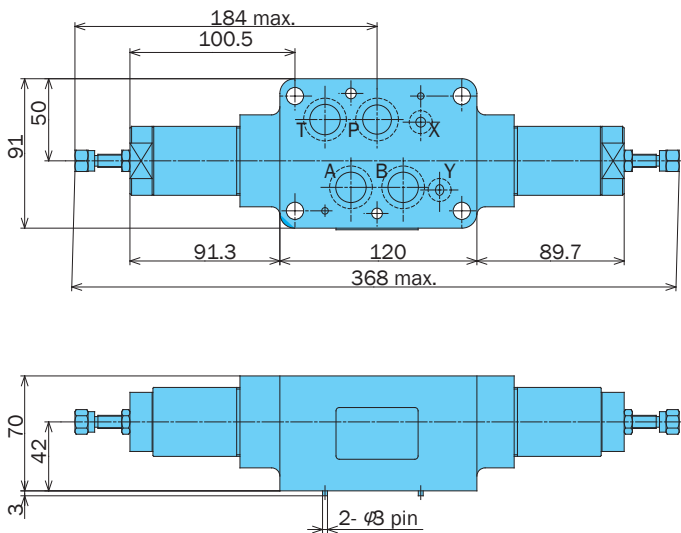

ORH-G04-DA*-10

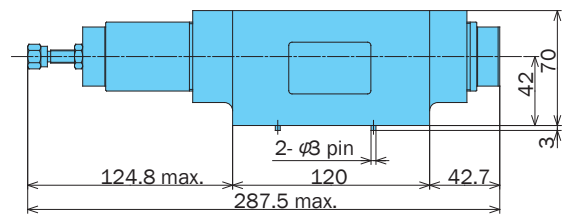

ORH-G04-DB*-10

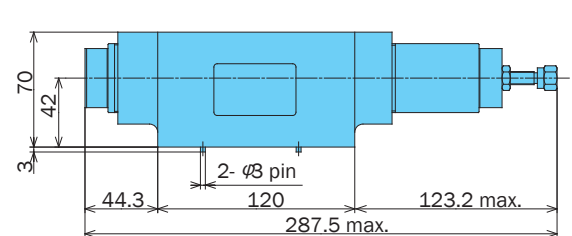

Performance Curves

Differential Hydraulic Fluid Viscosity 32 centistokes

Pressure - Flow Rate Characteristics

ORD-G01-**-20

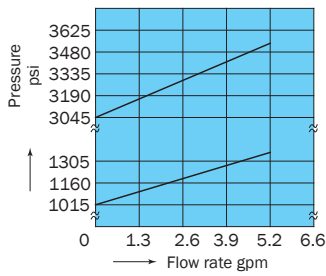

ORD-G03-**-J50

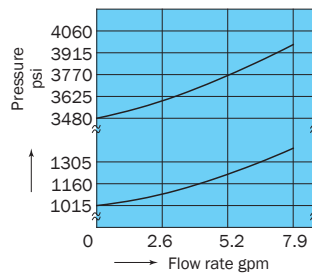

ORH-G04-DW*-10

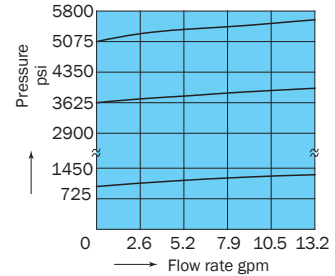

Number of Adjusting Screw Rotations - Pressure Characteristics

ORD-G01-**-20

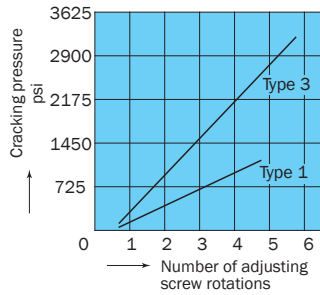

ORD-G03-**-J50

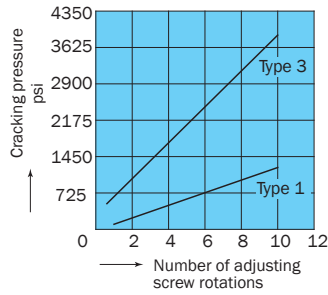

ORH-G04-DW*-10

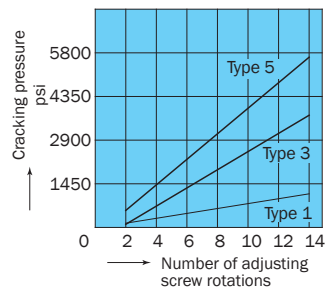

Cross-sectional Drawing

ORD-G01-A*-20

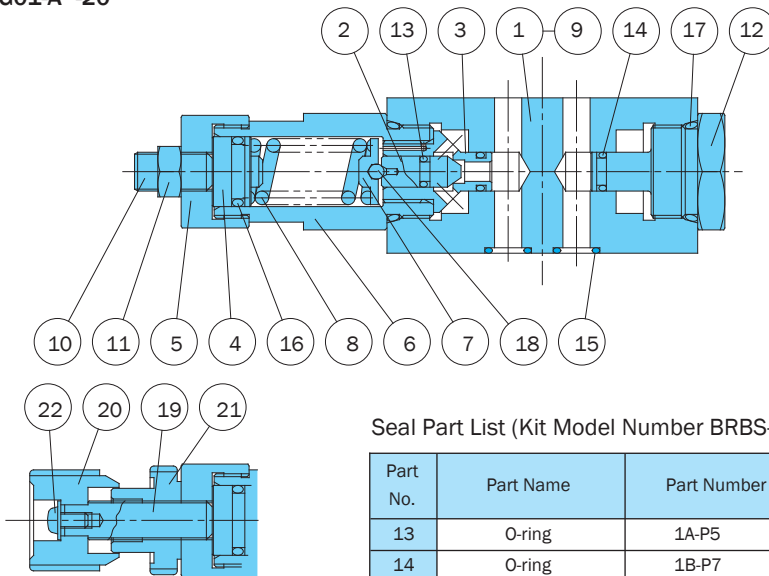

Seal Part List (Kit Model Number BRBS-01RD*)

Part No.	Part Name	Part Number	Q'ty		
			W	A	B
13	O-ring	1A-P5	2	1	1
14	O-ring	1B-P7	2	2	2
15	O-ring	1B-P9	4	4	4
16	O-ring	1B-P14	2	1	1
17	O-ring	1B-P22	2	2	2

Note: 1.O-ring 1A/B-**- refers to JIS B2401-1A/B.
2.Specify W, A, or B for the asterisk (*) in the kit model number.

Part No.	Part Name
1	Body
2	Poppet
3	Seat
4	Plunger
5	Bushing
6	Retainer
7	Guide
8	Spring
9	Plate
10	Screw
11	Nut
12	Bushing
13	O-ring
14	O-ring
15	O-ring
16	O-ring
17	O-ring
18	Ball
19	Screw
20	Knob
21	Nut
22	Screw

ORD-G03-A*-J50

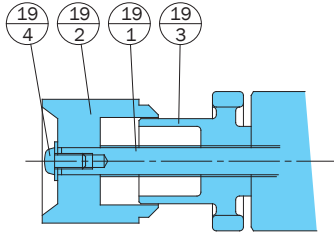
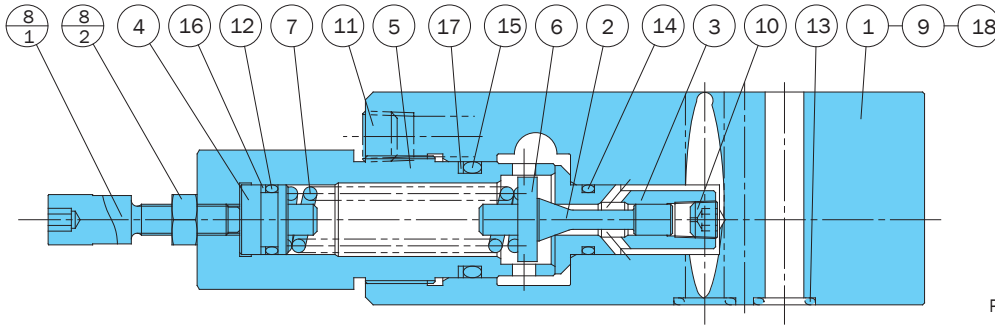

Seal Part List (Kit Model Number BRES-03RD*)

Part No.	Part Name	Part Number	Q'ty		
			A	B	W
12	O-ring	1A-P14	1	1	2
13	O-ring	AS568-014(Hs90)	5	5	5
14	O-ring	1B-P14	1	1	2
15	O-ring	1B-P24	1	1	2
16	Backup ring	T2-P14	1	1	2
17	Backup ring	T2-P24	1	1	2

Note) 1.O-ring 1A/B-** refers to JIS B2401-1A/B.
 2.Backup ring indicates JIS B2407-T2-**.
 3.Specify W, A, or B for the asterisk (*) in the kit model number

Part No. Part Name

1	Body
2	Poppet
3	Seat
4	Plunger
5	Retainer
6	Guide
7	Spring
8	Screw kit
8 ₁	Screw
8 ₂	Nut
9	Plate
10	Orifice
11	Plug
12	O-ring
13	O-ring
14	O-ring
15	O-ring
16	Backup ring
17	Backup ring
18	Pin
19	Handle kit
19 ₁	Screw
19 ₂	Knob
19 ₃	Nut
19 ₄	Screw

ORH-G04-DA*-10

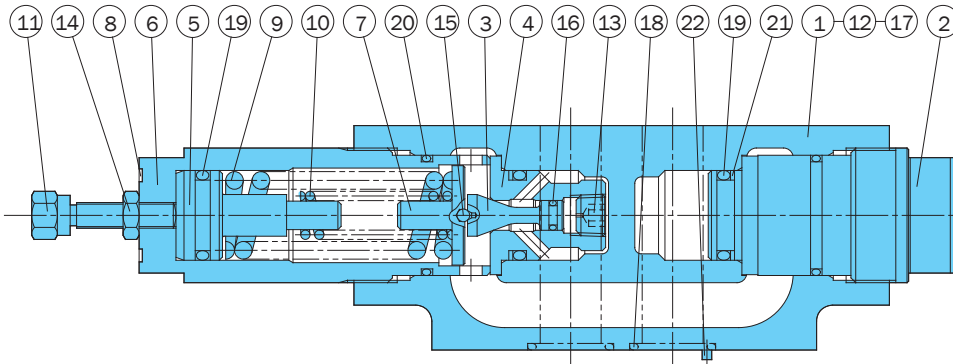

Seal Part List (Kit Model Number BRKS-04RD*)

Part No.	Part Name	Part Number	Q'ty		
			W	A	B
16	O-ring	1A-P6	2	1	1
17	O-ring	AS568-012(Hs90)	2	2	2
18	O-ring	AS568-118(Hs90)	4	4	4
19	O-ring	1B-P22A	4	3	3
20	O-ring	AS568-125(Hs70)	2	2	2
21	Backup ring	T2-P22A	2	2	2

Note) 1.O-ring 1A/B-** refers to JIS B2401-1A/B.
 2.Backup ring indicates JIS B2407-T2-**.
 3.Specify W, A, or B for the asterisk (*) in the kit model number.

Part No. Part Name

1	Body
2	Plug
3	Poppet
4	Seat
5	Plunger
6	Retainer
7	Guide
8	Plate
9	Spring
10	Spring
11	Screw
12	Plate
13	Choke
14	Nut
15	Ball
16	O-ring
17	O-ring
18	O-ring
19	O-ring
20	O-ring
21	Backup ring
22	Pin